

**4 BOSSES
TAPPED 10-32**

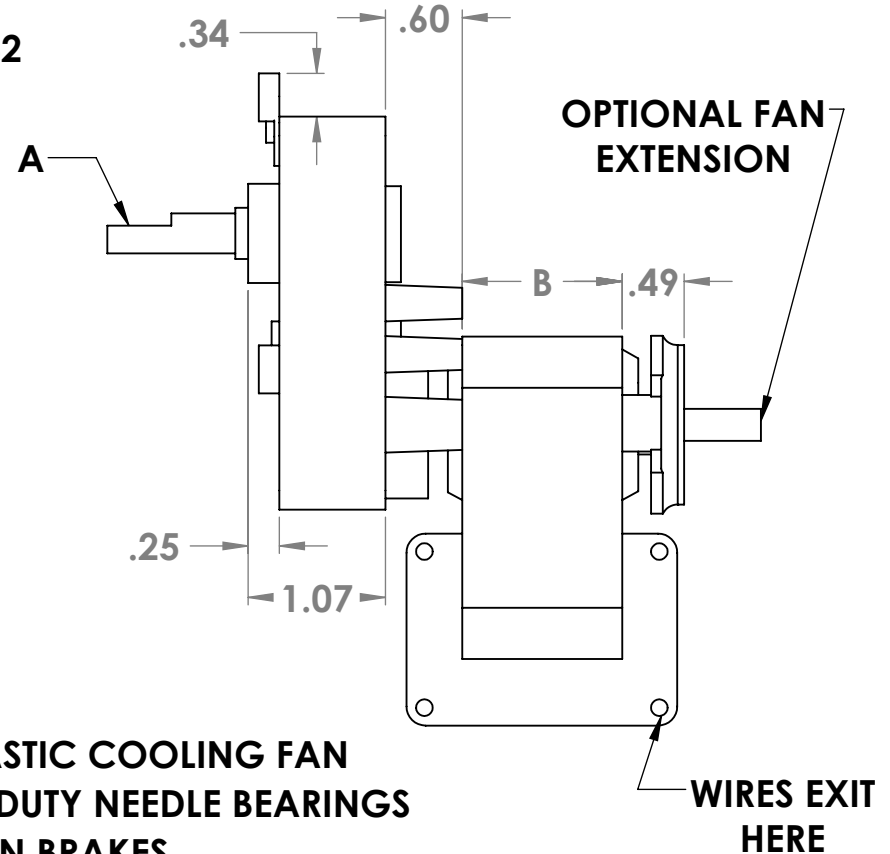

AC UNIDIRECTIONAL GEARMOTOR

- **A - OUTPUT SHAFT DESIGN PER CUSTOMER REQUIREMENTS**
- **B - 5/8"-2" DEPENDING ON RPM AND TORQUE REQUIREMENTS**
- **OUTPUT SPEEDS FROM 2-500 RPM**
- **OUTPUT TORQUE TO 50 IN. LB.**
- **24/120/240 VAC, 50/60 HZ**
- **CONTINUOUS OR INTERMITTANT DUTY**
- **SELF-RESETTING THERMAL PROTECTION**
- **U.L. & C.S.A APPROVED, C.E. MARKED**
- **18 GAUGE LEADS**

OPTIONS

- **2.5" PLASTIC COOLING FAN**
- **HEAVY DUTY NEEDLE BEARINGS**
- **FRICITION BRAKES**
- **TERMINALS**
- **ONE WAY CLUTCH**

UNLESS OTHERWISE SPECIFIED:		NAME	DATE	REX ENGINEERING	
DIMENSIONS ARE IN INCHES TOLERANCES: FRACTIONAL ± ANGULAR: MACH ± BEND ± TWO PLACE DECIMAL ± THREE PLACE DECIMAL ±		DRAWN	RPH 4/18		
INTERPRET GEOMETRIC TOLERANCING PER:		CHECKED		SIZE	
MATERIAL		ENG APPR.		DWG. NO.	
FINISH		MFG APPR.		REV	
DO NOT SCALE DRAWING		Q.A.		A CMN-D	
		COMMENTS:		SCALE: 2:3	
				WEIGHT:	
				SHEET 1 OF 1	